

Trimline 120 Front/Tunnel

A BEAUTIFUL FIREPLACE WITH REAL CLASS – MEDIUM SIZE



Product specifications

FEATURES



Balanced flue gas fire



Front model



Tunnel model



Double burner



Wood logs fuel bed



Ecomax remote control



Antracite steel panel interior



Lamelas interior

OPTIONALS



Pebbles fuel bed



Carrara fuel bed



Basalt fuel bed



Black glass interior



Anti reflective glass



Wide trims



Mains adapter GV60



Wall bracket remote control



Domotica smart connection



Wall switch



Set for app control



Puck control

The Trimline 120 Front or Tunnel is the perfect statement piece for your home, connecting not just rooms, but people as well. Make your house feel like a real home with this luxurious addition.

The standard version of the Trimline 120 Front/Tunnel has a burner bed made of wooden logs. On top of that, it comes with the Ecomax remote control and you have the options of adding Wi-Fi-control with our Trimline Fires app.



Styling & Optionals

Ecomax remote control

For absolute ease of use all appliances are supplied with an Ecomax remote system that controls the fire at the touch of a button.



Options interior finish materials and Trimline Wi-Fi control

For that extra WOW factor, there is also an option to upgrade to a different burner bed. Other available upgrades also include Wi-Fi.



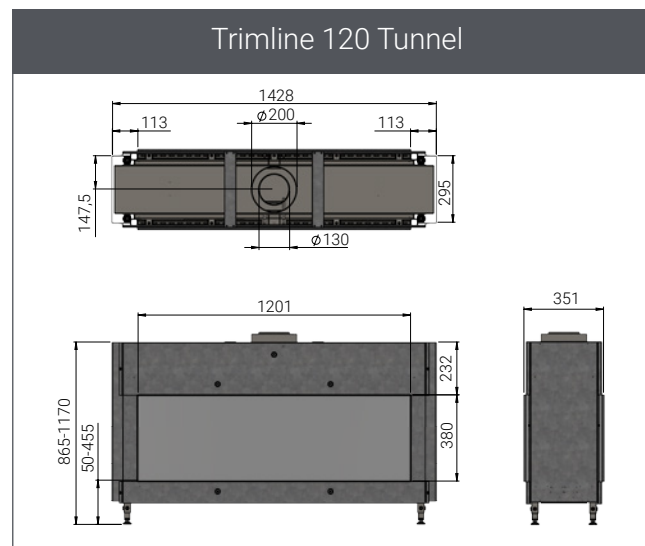
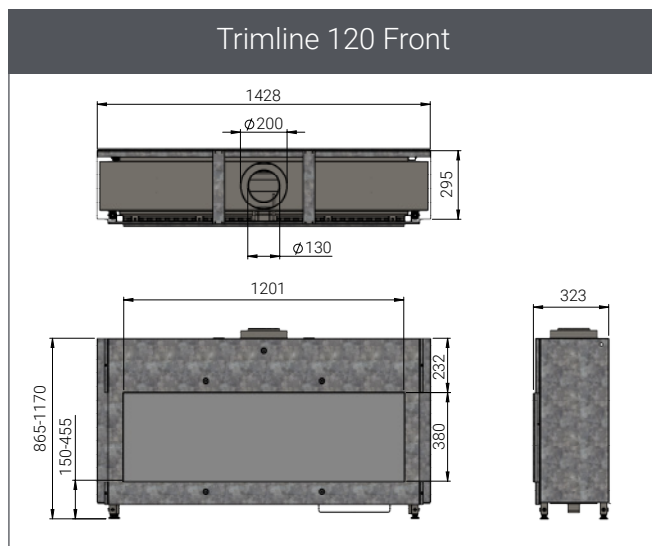

Appliance name	Trimline 120 Front/Tunnel			
Appliance type	Balanced flue built-in gas fires (C11, C31, C91)			
Purpose	Ambient heating, real flames			
Engine identification	1137 (F), 1138 (T)			
Gas type-pressure	Natural gas G25.3 – 25 mbar	Natural gas G20 – 20 mbar	Natural gas G25 – 20 mbar	LPG G30/31 – 28-50 mbar
Heat input (kW)	12	12.8	10.5	10.2
Heat output max (kW)	9.2	10.1	8	8
Heat output min (kW)	4.2	4.6	3.6	3.6
Consumption (m ³ /h and kg/h LPG)	1.45	1.36	1.29	0.6
Efficiency (%)	77	79	77	78
Energy label highest efficiency	B	B	B	B
Flue lay out wall termination	Indirect 1m vertical and max 5,5m horizontal			
Weight (kg)	Front 145/Tunnel 130			
Efficiency class EN613	2			
NOx Class	5			
PIN ID CE	0461CP1031			
Gas connection	3/8" outside connection			
Electrical connection	6 VDC battery powered			
Gas control system	Mertik Maxitrol SYMAX B6R radio controlled 866 mHz			
Safety	Thermocouple flame supervision and pressure hatches			
Heat distribution	Internal convection system			
Connectivity	Optional App control (Android and IOS), wall switch and domotica connection			
Flue type and diameter	Holetherm-CC concentric flue 130-200mm			
Standard supplied	Adjustable legs – Convection chamber and grills – Wall brackets – Log set			
Optional	See products specifications			
Remarks	Always use non-combustible construction materials such as metal stud framing and fireboard cladding			

Installation details

Concentric flue system

Using the THC-CC double wall chimney system the flue gases are safely transported to the outside and fresh combustion-air is pulled inside the appliance. Balanced flue appliances can be installed using a wall terminal so no traditional chimney is needed. THC-CC is made of high quality stainless steel and approved according CE standards in combination with the Trimline appliances.



Balanced flue gas fire

One of the most innovative aspects of the Trimline 120 Front/Tunnel is that there is no need for an existing chimney to be present. This is all down to the clever features of our balanced flue gas fire, that is fully room sealed. Not only does this make for a highly efficient and safe appliance, but when combined with our concentric flue system, our fires can be positioned in virtually any part of your home with a relatively simple 'chimney breast' built around it. A direct wall outlet from the back of the fire makes the installation even easier.