



**CATALOG**

# **OUTDOOR UNIT COVER**





# About Devaux

Custom high-end decorative metalwork

Founded in 1946 and based in Saint-Michel-sur-Meurthe in the Vosges mountains, Devaux has been crafting high-quality metal components with exceptional expertise for decades. Their products are renowned for combining durability, functionality, and elegant design, reflecting a long tradition of craftsmanship.

Every piece is carefully manufactured, using premium materials, precise assembly, and rigorous quality control to ensure the highest standards.

Through our collaboration with Devaux, DHK Products proudly offers reliable, stylish, and long-lasting solutions that combine traditional craftsmanship with modern design.



# Table of contents

Page	Content
<b>5</b>	<b>Outdoor unit covers</b>
8	Assembly
10	Standard range
11	Dimensions
15	Models
17	Modular
21	Customization
<b>25</b>	<b>Noise protection solutions</b>
27	Noise protection system Cube
<b>31</b>	<b>Custom manufacturing</b>
32	Custom projects



# Outdoor unit covers

Devaux air conditioning covers are designed and manufactured in the Vosges region of France.

Our products are rooted in artisanal expertise and an industrial structure.



Lifetime warranty



100% PEFC Pine Vosges forest



100% aluminum



Special UV-resistant paint



## Why choose a devaux air conditioning cover?

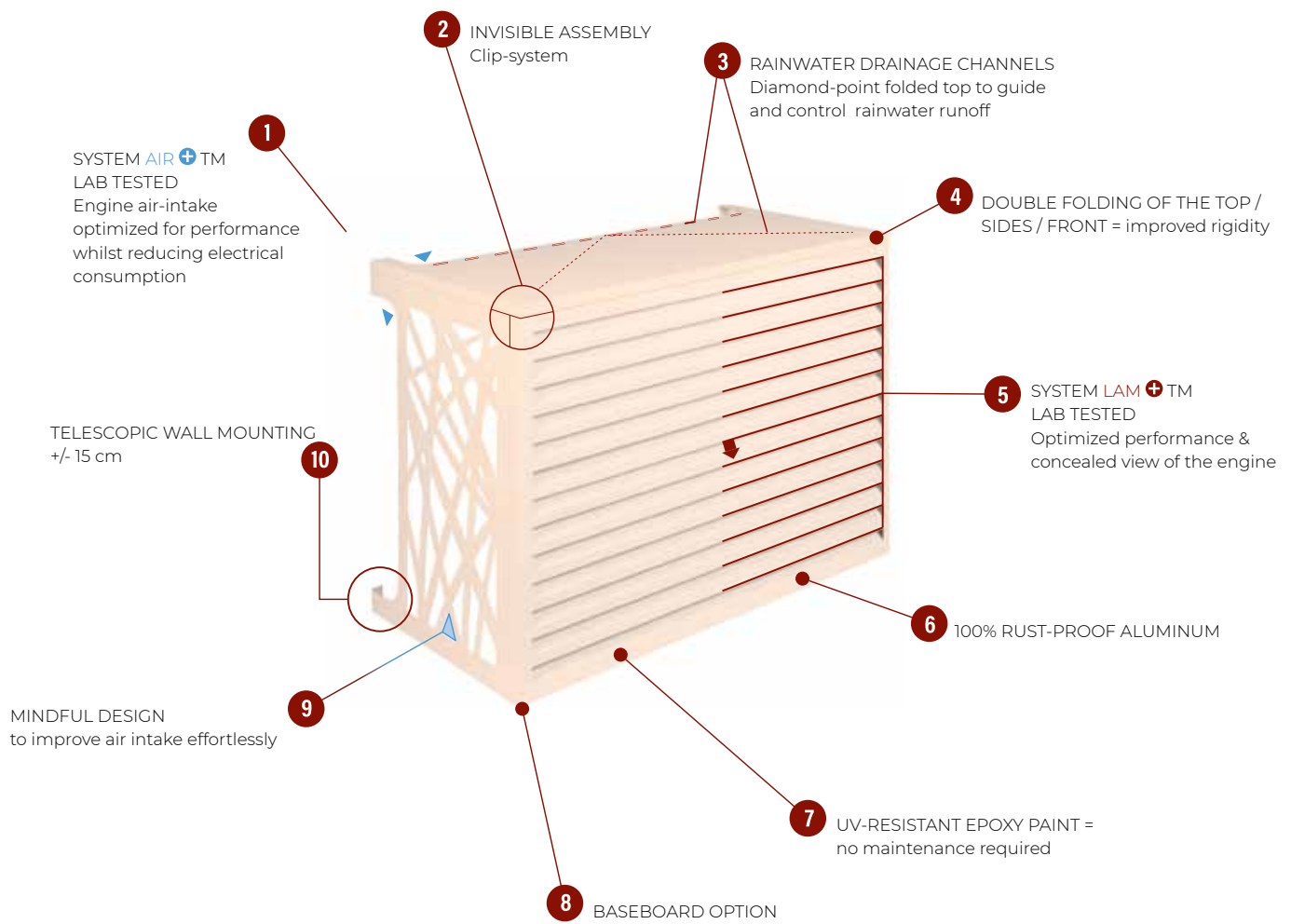



## Products +



### QUICK & EASY ASSEMBLY

Simple and efficient installation in less than 2 minutes + mounting. Follow the instructional video to easily install your air conditioning cover!



### MAINTANANCE-FREE & EASY TO DISASSEMBLE FOR SERVICE-RELATED PURPOSES

Easy to disassemble to access your air conditioner / heat pump engine unit during maintenance.



### PROTECTS CHILDREN & ANIMALS

Ensure the safety of your children and pets by installing a completely secure air conditioner cover that keeps them away



### PROTECTS AGAINST IMPACTS & WEATHER CONDITIONS

Rainwater channeling with folds and drainage holes. Reduces engine fouling



### CUSTOM SIZES & COLORS

SIZES :

**XS** **S** **M** **L** **XL** **2XL** **3XL** **4XL**

see page 19  
or custom-made

STANDARD COLORS :  
cream RAL9001 or anthracite grey RAL7016

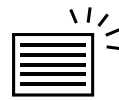

### CAMOUFLAGES THE UNIT WITHOUT IMPACTING AERODYNAMIC PERFORMANCE

The installation of a Devaux air conditioning cover ensures a discrete integration of a heat pump into the environment without impacting its performance.

Compatible with major air conditioner brands



# Assembly

quick & easy

2 min + wall mounting

Follow the installation steps



CHECK OUT THE ASSEMBLY DEMONSTRATION



Transform technical necessity into a design statement your customers will love



Before



After



Before



After



Before



After



Before



After

# Standard range

MIXED MODELS



ANTHRACITE GREY RAL 7016    CREAM RAL 9001

**XS**   **S**   **M**   **L**   **XL**   **2XL**   **3XL**   **4XL**

see page 15

4 SIDES PERFORMANCE MODELS



ANTHRACITE GREY RAL 7016    CREAM RAL 9001

**S**

see page 15

PERFORMANCE MODELS



ANTHRACITE GREY RAL 7016    CREAM RAL 9001

**XS**   **S**   **M**   **L**   **XL**   **2XL**   **3XL**   **4XL**

see page 16

# Dimensions

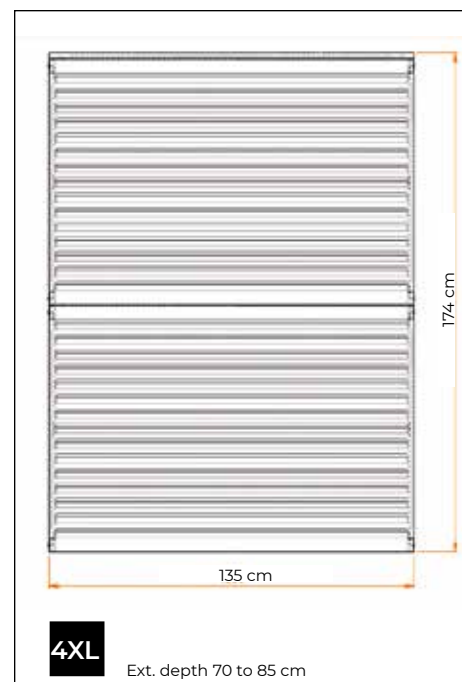
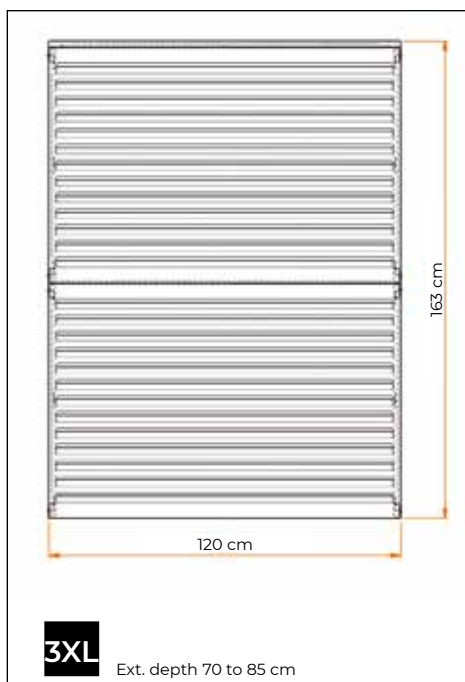
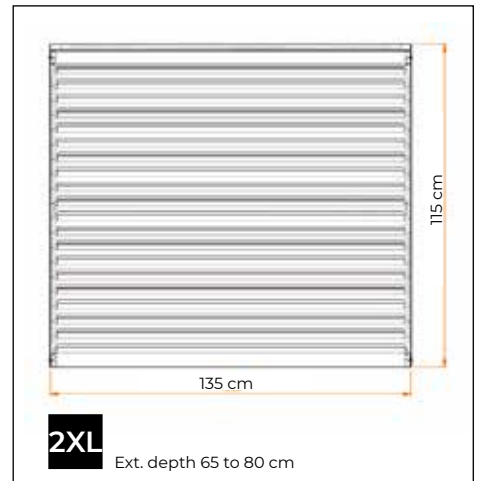
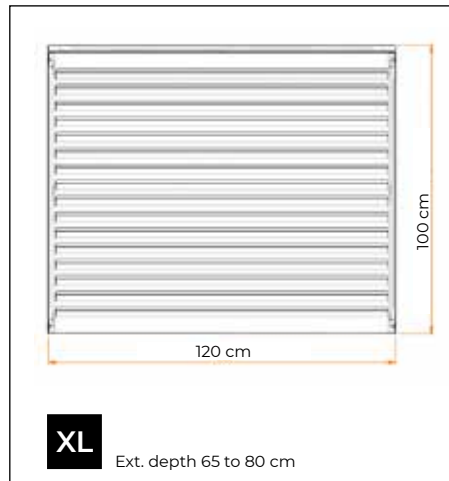
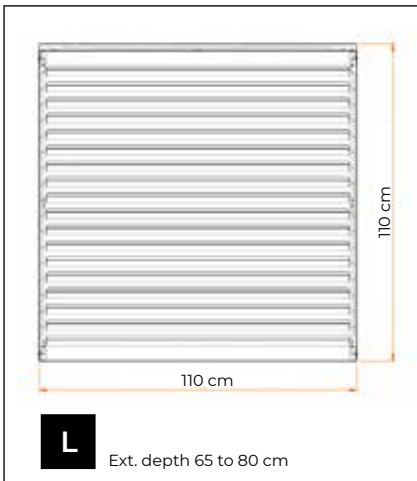
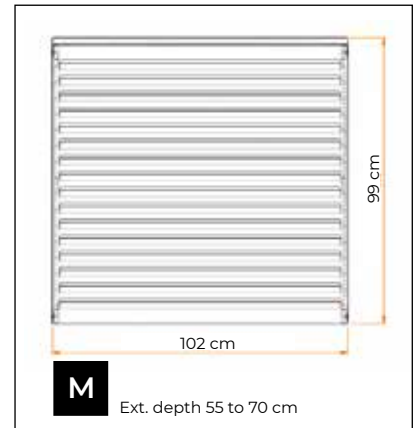
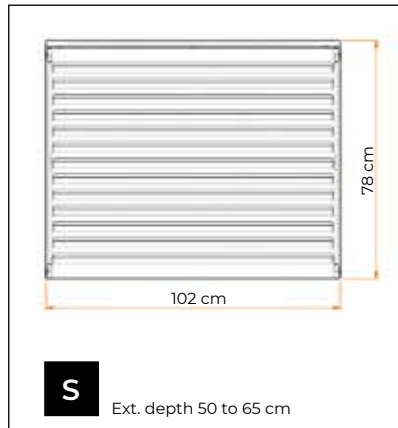
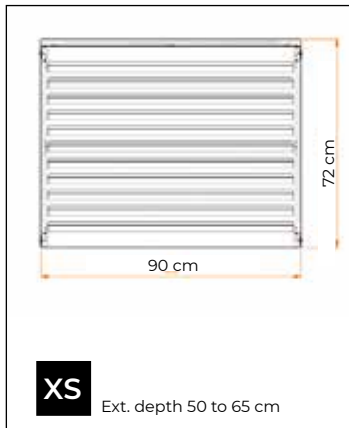





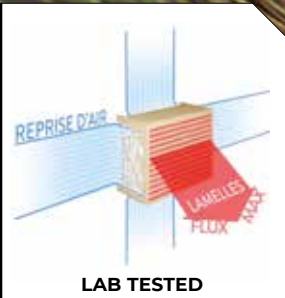

## MIXED MODEL

OPTIMIZED AIRFLOW  
for models with slats

Devaux's design team has optimized natural ventilation to achieve the perfect balance between elegant design and technical performance.



# Models

## MIXED MODELS

Made from aluminium, ensuring a completely rust-free solution.

SYSTEM AIR+™ LAM+™



Telescopic depth +/-15 cm

Size	Ref	Ext. dimensions (in cm)			Int. dimensions (in cm)			Colours
		Width	Height	Depth	Width	Height	Depth	
XS	DHK5200013	90	72	50 - 65	85	70	47 - 62	Anthracite grey
	DHK5200014							Cream
S	DHK5200015	102	78	50 - 65	97	76	47 - 62	Anthracite grey
	DHK5200016							Cream
M	DHK5200017	102	99	55 - 70	97	97	52 - 67	Anthracite grey
	DHK5200018							Cream
L	DHK5200019	110	110	65 - 80	105	108	62 - 77	Anthracite grey
	DHK5200020							Cream
XL	DHK5200021	120	100	65 - 80	115	98	62 - 77	Anthracite grey
	DHK5200022							Cream
2XL	DHK5200023	120	163	70 - 85	115	161	67 - 82	Anthracite grey
	DHK5200024							Cream
3XL	DHK5200025	135	115	65 - 80	130	113	62 - 77	Anthracite grey
	DHK5200026							Cream
4XL	DHK5200027	135	174	70 - 85	130	172	67 - 82	Anthracite grey
	DHK5200028							Cream

## PERFORMANCE MODELS

Made from aluminium, ensuring a completely rust-free solution.

The slats ensure maximum airflow while fully concealing the unit and optimizing its protection.

SYSTEM AIR+™ LAM+™



Telescopic depth +/-15 cm

Size	Ref	Ext. dimensions (in cm)			Int. dimensions (in cm)			Colours
		Width	Height	Depth	Width	Height	Depth	
XS	DHK5200001	90	72	50 - 65	85	70	47 - 62	Anthracite grey
	DHK5200002							Cream
S	DHK5200003	102	78	50 - 65	97	76	47 - 62	Anthracite grey
	DHK5200004							Cream
M	DHK5200103	102	99	55 - 70	97	97	52 - 67	Anthracite grey
	DHK5200005							Cream
L	DHK5200006	110	110	65 - 80	105	108	62 - 77	Anthracite grey
	DHK5200007							Cream
XL	DHK5200109	120	100	65 - 80	115	98	62 - 77	Anthracite grey
	DHK5200155							Cream
2XL	DHK5200008	120	163	70 - 85	115	161	67 - 82	Anthracite grey
	DHK5200009							Cream
3XL	DHK5200105	135	115	65 - 80	130	113	62 - 77	Anthracite grey
	DHK5200010							Cream
4XL	DHK5200011	135	174	70 - 85	130	172	67 - 82	Anthracite grey
	DHK5200012							Cream

## PERFORMANCE MODELS 4 SIDES | SELF-SUPPORTING

Aluminium made, results in a rust-free project.

SYSTEM AIR ™ LAM ™

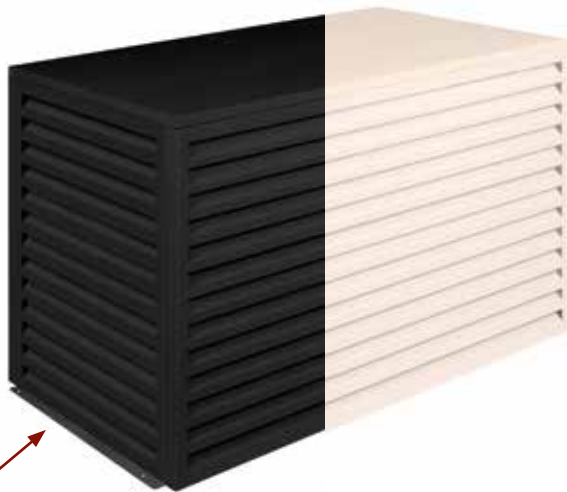

Outer edges for ground fixation

Size	Ref	Ext. dimensions (in cm)			Int. dimensions (in cm)			Colours
		Width	Height	Depth	Width	Height	Depth	
S	DHK526010076A	100	76	60	95	75	55	Anthracite grey
	DHK5200106							Cream



# Modular

Seamless alignment in modular installations



## BASEBOARDS

With rainwater drainage



Aluminum baseboard to be attached underneath the air conditioner cover for elevated installations.

Standard colors: cream RAL 9001 or anthracite grey RAL 7016  
Customized colors and sizes available upon request.



Ref	Ext. dimensions	Colours
DHK5200029	L 90 X H 2,5 X P 50 CM	Anthracite grey
DHK5200030		Cream
DHK5200031	L 102 X H 2,5 X P 50 CM	Anthracite grey
DHK5200032		Cream
DHK5200033	L 102 X H 2,5 X P 55 CM	Anthracite grey
DHK5200034		Cream
DHK5200035	L 110 X H 2,5 X P 65 CM	Anthracite grey
DHK5200036		Cream
DHK5200087	L 120 X H 2,5 X P 65 CM	Anthracite grey
DHK5200092		Cream

## ELEVATION AND GROUND FIXATION OPTION

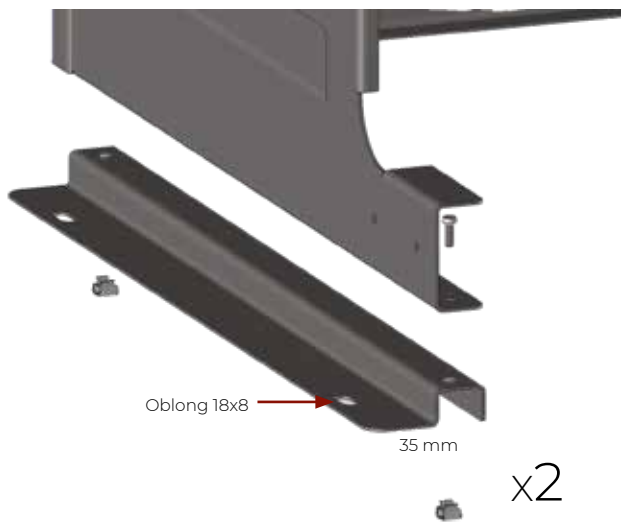

Reversible aluminium support to mount the air conditioner cover to the ground and/or allow for condensate drainage.

Elevation height: 25 mm

Ground fixation holes diameter: 8 mm

Elevation can be installed in two ways: outward or inward

Size	Ref	Ext. dimensions (in cm)			Colours
		Width	Height	Depth	
XS S	DHK5200039	2,5 + 3,5	2	50	Anthracite grey
	DHK5200040				Cream
M	DHK5200041	2,5 + 3,5	2	55	Anthracite grey
	DHK5200042				Cream
L XL 2XL	DHK5200043	2,5 + 3,5	2	65	Anthracite grey
	DHK5200044				Cream
3XL 4XL	DHK5200045	2,5 + 3,5	2	70	Anthracite grey
	DHK5200046				Cream

## CONDENSATE REMOVABLE DRAWERS

Ref	Ext. dimensions	Colours
DHK5200047	L 90 X H 5 X P 50 CM	Anthracite grey
DHK5200048		Cream
DHK5200049	L 102 X H 5 X P 50 CM	Anthracite grey
DHK5200050		Cream
DHK5200051	L 102 X H 5 X P 55 CM	Anthracite grey
DHK5200052		Cream
DHK5200053	L 110 X H 5 X P 65 CM	Anthracite grey
DHK5200054		Cream
DHK5200055	L 120 X H 5 X P 65 CM	Anthracite grey
DHK5200056		Cream

Aluminum drawer to be fixed using 2 rails underneath the air conditioner cover of your choice

Standard colors: cream RAL 9001 or anthracite grey RAL 7016

Customized colors and sizes available upon request





# Customization

## CUSTOM SIZES AND COLORS

The rustproof aluminum air conditioner covers are available in multiple colors.  
Discover the color chart below.



## CUSTOMIZED PROJECTS

for developers & architects



## CUSTOM-MADE VENTS

Custom manufacturing of electro-galvanized steel grids.  
Fixed or closable with a door on a hinge.



Custom-made only



# PROTECTIVE COVER



Custom-made only



Contact us for pricing

**Products +**  
Damage resistance and security.  
Ideal for parking lots and  
public spaces.

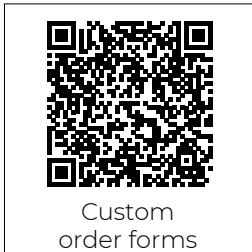



# Noise protection solutions

Quality

100% French manufacturing

The acoustic cube does not eliminate noise entirely, but significantly reduces sound levels by creating an effective acoustic shield around the unit.



Air conditioner and  
heat pump noise

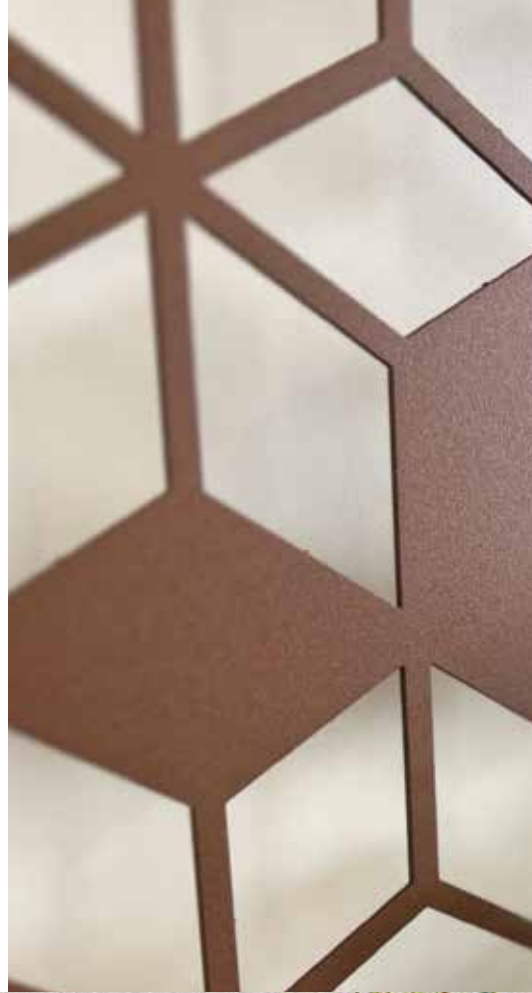

# Noise protection system Cube

## COLOURS & TEXTURES



Single Cube



Angled Cube



Single Cube with HEXA decor option



Single Cube with WOOD decor option



Cream 9001



Anthracite grey 7016



Rust colour



Bottle green 6007

Ref	Name	Ext. dimensions (in cm)			Colours
		Width	Height	Depth	
DHK5200057	Acoustic single cube	50	50	12	Cream 9001
DHK5200058					Anthracite grey 7016
DHK5200059					Rust colour
DHK5200060					Bottle green 6007
DHK5200061	Acoustic angled cube 50 50 50	50	50	50	Cream 9001
DHK5200062					Anthracite grey 7016
DHK5200063					Rust colour
DHK5200064					Bottle green 6007
DHK5200065	Hexa metal decor option for single cube	49	49	4	Cream 9001
DHK5200066					Anthracite grey 7016
DHK5200067					Rust colour
DHK5200068					Bottle green 6007
DHK5200069	Wood decor option for single cube	49	49	7	Cream 9001
DHK5200070					Anthracite grey 7016
DHK5200071					Rust colour
DHK5200072					Bottle green 6007
DHK5200073	Planter option for single cube	50	50	50	Cream 9001
DHK5200074					Anthracite grey 7016
DHK5200075					Rust colour
DHK5200076					Bottle green 6007

## STABILIZATION

Add our stabilizing solutions  
Recommended for wind-exposed sites



Cube + Planter option 50 x 50 x 50 cm  
for adding greenery and  
stabilizing your installation.



Mounting-kit includes

- ▶ 1 aluminum baseplate
- ▶ 1 stainless steel cable, 2 m long

## ACOUSTIC PERFORMANCE

Reduction up to 10 - 15 dB  
at 1 m, 5 m, and 10 m

The acoustic cube doesn't eliminate noise, but it protects an area by creating an acoustic shield. The installation must be designed around the motor and allow access for maintenance, to protect the critical area and ensure sufficient air circulation. The noise emission of a heat pump in heating mode is around 60dB.

Results obtained through real-world expertise, varying depending on the installed motor brand, its frequency, and its environment.

## INSTALLATION

Speed, simplicity, and modularity!



## TECHNICAL INFORMATION

Aluminum cubes

Combine as desired to protect an area from the noise generated by a heat pump motor

- ▶ Aluminum cubes with textured EPOXY paint for a sturdy, rust-resistant product.
- ▶ Soundproof insulation made of rock wool, lined with a geotextile fabric to protect the insulation and allow the product to remain outdoors all year round.
- ▶ Mounting-kit (optional) for anchoring to a wall, the ground, or directly onto the heat pump.



▶ **Angled Cube**  
3 mm thick  
aluminum  
50 x 50 x 50 cm ext.

▶ **Rock wool insulation**  
with geotextile fabric  
(rain protection)  
Pre-glued  
Provided with the cube

▶ **Single Cube**  
3 mm thick  
50 x 50 cm ext.



# Custom manufacturing

Quality

100% French manufacturing

LASER cutting

Bending

Welding of steel, stainless steel, aluminum

Liquid or Epoxy paint

Packing and shipping throughout Europe

# Custom projects

Example of custom projects



1

Measurements taken by the professional installer



2

Quote, validation, drawing by DEVAUX to be signed by the installer.

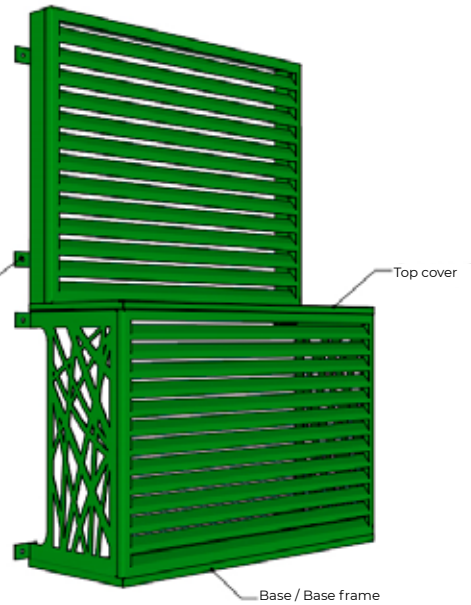

4

Installation by the professional.



3

Manufacturing and dispatch within 1 to 4 weeks.

# Custom projects

Example of custom projects



1

Measurements taken by the professional installer.

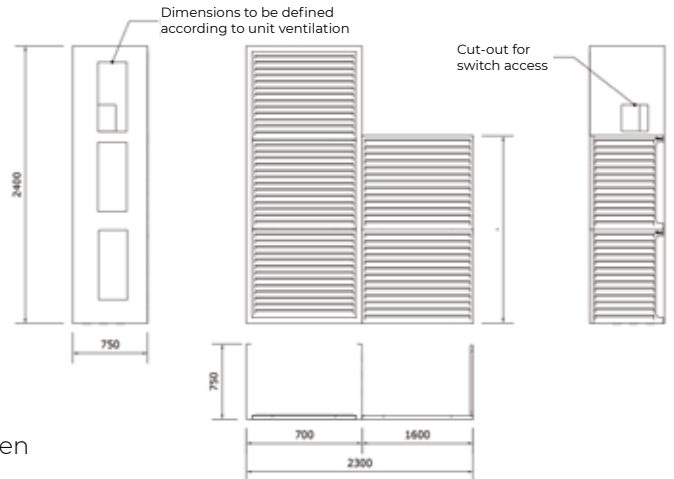

2

Quote, validation and plan implementation by Devaux to be signed by the installer.



3

Installation by the professional.



## We are DHK

DHK Products is a trusted full-range supplier of accessories and installation supplies for the stove and fireplace industry. We serve professionals — including installers, specialist fireplace retailers and chimney sweeps — as well as consumers, with a complete and carefully curated product range, available directly from stock. This ensures fast delivery, continuity, and consistent quality.

By offering everything under one roof, DHK supports trade professionals with reliable, high-quality products that make installation and maintenance work more efficient and worry-free. Our focus on long-term partnerships, purchasing advantages and an efficient supply chain allows craftsmen to work with confidence, while end users benefit from comfort, safety and ease of use.

## Part of a larger collective

DHK Products is part of the IHS Group, where the strengths of six powerful brands come together. This collective enables us to provide customers with innovative, high-quality, and sustainable solutions, while benefiting from shared expertise, combined purchasing power, and optimised logistics.

Within the IHS Group, we continuously invest in the sustainability of our product portfolio and production processes, and in building long-term partnerships with our customers and business partners.





**DHK Products**

Laagerfseweg 27/29  
3931PC Woudenberg  
Netherlands

+31 33 286 1075  
sales@ihs-group.com  
www.dhkproducts.com